



**Electrolux**  
PROFESSIONAL

**Modular Cooking Range Line  
700XP Electric Hob Cooking Top  
800 mm**

ITEM # \_\_\_\_\_

MODEL # \_\_\_\_\_

NAME # \_\_\_\_\_

SIS # \_\_\_\_\_

AIA # \_\_\_\_\_

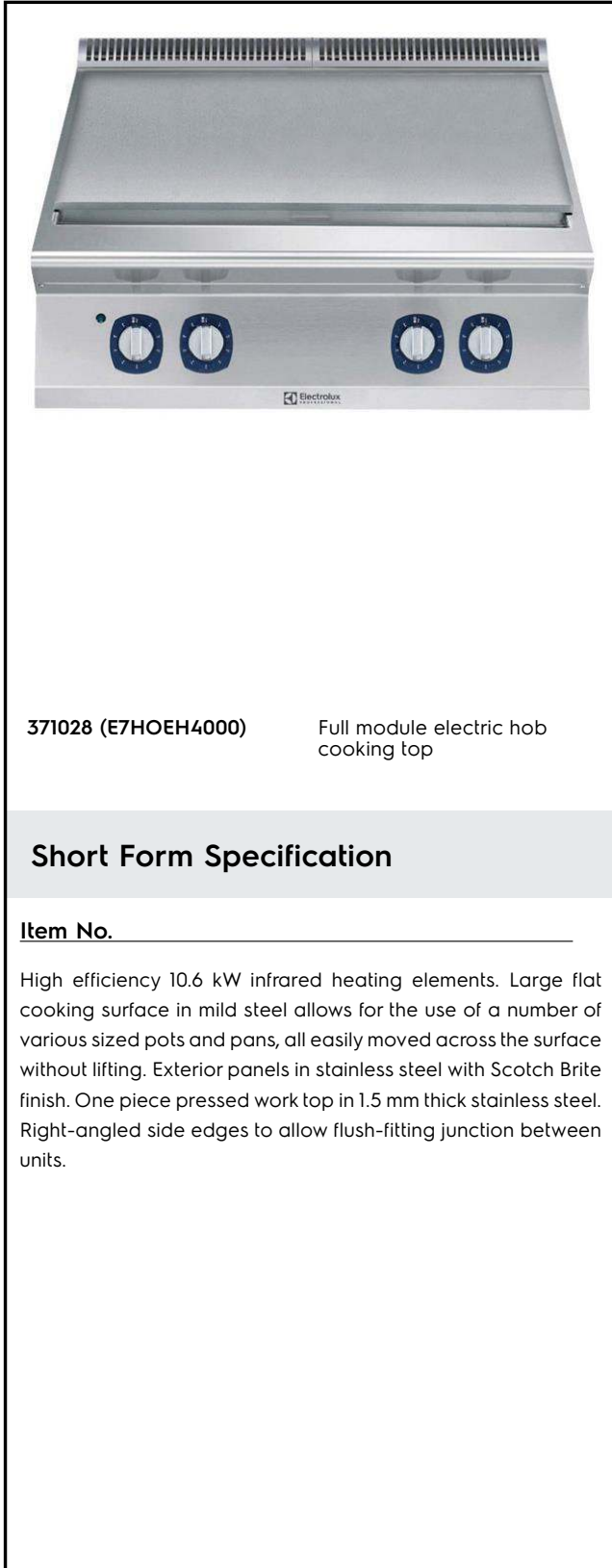

371028 (E7HOEH4000)

Full module electric hob cooking top

**Short Form Specification**

Item No. \_\_\_\_\_

High efficiency 10.6 kW infrared heating elements. Large flat cooking surface in mild steel allows for the use of a number of various sized pots and pans, all easily moved across the surface without lifting. Exterior panels in stainless steel with Scotch Brite finish. One piece pressed work top in 1.5 mm thick stainless steel. Right-angled side edges to allow flush-fitting junction between units.

**Main Features**

- 10.6 kW infrared heating elements can reach a maximum temperature of 400°C.
- Durable mild steel cooking plate, easy to clean.
- Various sizes of pans can be used at the same time due to large surface area with no intermediate sectors.
- Pans can easily be moved from one area to another without lifting.
- All major compartments located in front of unit for ease of maintenance.
- Top configuration allows installation on ambient base only (not possible to install on refrigerated nor freezer base).
- Suitable for countertop installation.

**Construction**

- All exterior panels in Stainless Steel with Scotch Brite finishing.
- One piece pressed 1.5 mm work top in Stainless steel.
- Model has right-angled side edges to allow flush fitting joints between units, eliminating gaps and possible dirt traps.
- IPx4 water protection.

**Optional Accessories**

- Junction sealing kit PNC 206086
- Draught diverter with 150mm diameter PNC 206132
- Matching ring for flue condenser PNC 206133
- Support for bridge type system, 800mm PNC 206137
- Support for bridge type system, 1000mm PNC 206138
- Support for bridge type system, 1200mm PNC 206139
- Support for bridge type system, 1600mm PNC 206141
- Water column with swivel arm (water column extension not included) PNC 206289
- Water column extension for 700 line PNC 206291
- Right and left side handrails PNC 206307
- 2 single portion baskets for automatic programmable pasta cooker PNC 206312
- Chimney grid net, 400mm PNC 206400
- Frontal handrail 800mm PNC 216047
- Frontal handrail 1200mm PNC 216049
- Frontal handrail 1600mm PNC 216050
- Large handrail - portioning shelf, 800mm PNC 216186
- 2 side covering panels for top appliances PNC 216277

APPROVAL: \_\_\_\_\_



Experience the Excellence  
[www.electroluxprofessional.com](http://www.electroluxprofessional.com)

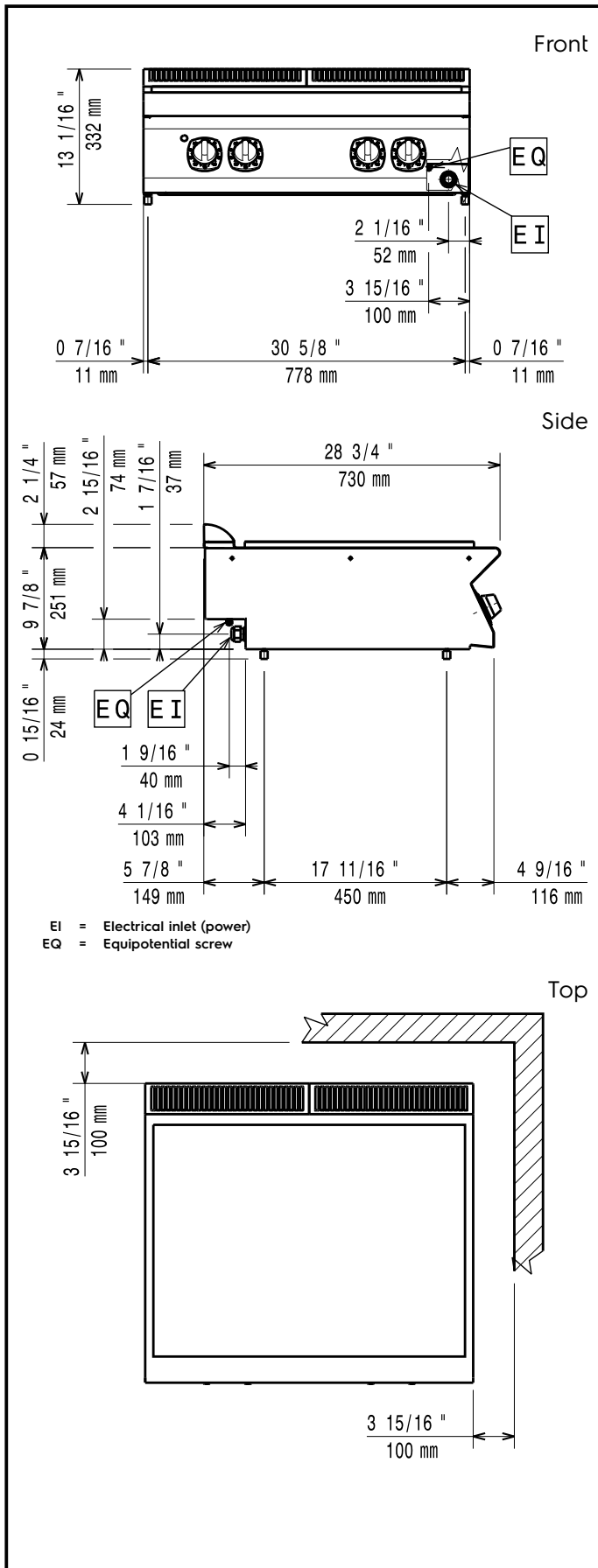

## Electric

Supply voltage:	380-400 V/3N ph/50/60 Hz
Rated amps:	0 A
Predisposed for:	380-400V 3N~ 50/60Hz
Total Watts:	9-10kW
	10 kW

## Key Information:

If appliance is set up or next to or against temperature sensitive furniture or similar, a safety gap of approximately 150 mm should be maintained or some form of heat insulation fitted.

External dimensions, Width:	800 mm
External dimensions, Depth:	730 mm
External dimensions, Height:	250 mm
Net weight:	71.5 kg
Shipping weight:	80 kg
Shipping height:	530 mm
Shipping width:	820 mm
Shipping depth:	860 mm
Shipping volume:	0.37 m <sup>3</sup>
Certification group:	N7ETE
Solid top usable surface (width):	760 mm
Solid top usable surface (depth):	565 mm